

Instruction Manual

Blood Bank Refrigerator DRS-500

Japanese Medical Device Certification Number:21900BZX00008000

Contents	Page
1. Precautions for Safe Operation	1
2. Installation	4
3. Caution for Usage	5
4. Introduction	7
5. Equipment Overview	7
6. Front Panel Nomenclature	8
7. Before Operating	9
8. Shut Down	10
9. Alarms	10
10. Defrost	12
11. Circuit Breaker	12
12. Temperature Precision	13
13. Care	13
14. When Not Using	14
15. Troubleshooting	15
16. Specifications	16

 **Daido Industries INC.**

1-6-45 Kusune, Higashi-Osaka,

Osaka, 577-0006 Japan

1. Precautions for Safe Operation

It is imperative that the user complies with this manual as it contains important safety advice.

Items and procedures are described herein for the correct and safe operation of this unit. Following the precautions as advised will prevent possible injury to the user and other persons.

Precautions are illustrated in the following way:



WARNING

Failure to observe WARNING signs could result in a hazard to personnel possibly resulting in serious injury or death.



CAUTION

Failure to observe CAUTION signs could result in injury to personnel and possibly damage to the unit and associated property.

Explanation of symbols:



Denotes caution.



Denotes a prohibited action.



Denotes an instruction that must be followed.

Be sure to keep this manual in a place accessible to users of this unit.













Labels on the unit













This mark is labeled on covers where high voltage electrical components are enclosed to prevent the electric shock. Covers should be removed by qualified engineers or service personnel only.



Warning

-  **Only qualified engineers or service personnel should install the unit.** Installation by unqualified personnel may result in electric shock or fire.
-  **Install the unit on a sturdy floor.** If the floor is not strong enough, or if the installation site is inadequate, the unit may fall or tip over and cause injury.
-  **Use a grounded (earthed) power supply outlet** to prevent electric shock. If the power supply outlet is not grounded, a qualified engineer will need to install a ground.
-  **Never ground the unit through a gas pipe, water main, telephone line, or lightning rod.** Such grounding may cause electric shock in the case of an incomplete circuit.
-  **Use a dedicated power source** as indicated on the rating label attached to the unit. **A branched circuit may cause a fire due to abnormal heating.**
-  **Connect the unit to a power source as indicated on the rating label attached to the unit.** Use of any voltage or frequency other than that on the rating label may result in fire or electric shock.
-  **Do not use the unit outdoors.** Current leakage or electric shock may result if the unit is exposed to rainwater.
-  **Never install the unit in a humid place or where there is likely to be contact with water.** It may deteriorate the insulation, resulting in current leakage or electric shock.
-  **When removing the plug from the power supply outlet, grip the power supply plug,** not the cord. Pulling the cord may result in electric shock or fire from short circuit.
-  **Never damage or break the power supply plug or cord. Do not use the supply plug if its cord is loose.**
-  **Do not touch any electrical parts such as the power supply plug or any switches with a wet hand.** This may result in electric shock.
-  **Remove debris from the power supply plug** before inserting into a power source. A dirty plug or improper insertion may pose a hazard.

Warning

-  **Never install the unit in a flammable or volatile location.** This may result in an explosion or fire.
-  **Never put volatile or flammable substances in this unit.** This may result in an explosion or fire.
-  **Never install the unit where acid or corrosive gases are present,** as current leakage or electric shock may result due to corrosion.
-  **Never put corrosive substances on this unit.** This may result in damage to the components or electric parts.
-  **Do not insert metal objects such as pins or wires into any vent, gap, or outlet for inner air circulation.** This may cause electric shock or injury from accidental contact with moving parts.
-  **Do not climb onto the unit.** This may cause damage to the unit.
-  **Do not touch the condenser directly** when the filter is removed for cleaning. This may result in injury from the hot surface.
-  **Disconnect the power supply plug** before moving the unit. Take care not to damage the power cord. A damaged cord may cause electric shock or fire.
-  **Dispose of any water in the evaporation tray completely before moving the unit.** Spilled or splashed water may cause current leakage or electric shock.
-  **Disconnect the power supply plug** when the unit is not in use for long periods.
-  **Do not put the packing plastic bag used in the packaging within reach of children** as it may result in suffocation.

2. Installation

To operate this unit properly and to obtain maximum performance, install the unit in a location with the following conditions

■ Usable ambient temperature

- ⚠ Use in Ambient temperature 15°C to 30°C. Out of this ambient temperature may cause the inadequate cooling or not to keep low temperature. Especially at the place over 35°C, heat dissipation may cause not only inadequate cooling but also short the life of the unit.

■ A location with a sturdy and level floor

- ⚠ Install the unit on a sturdy floor. If the floor is not strong enough or the installation site is not adequate, this may result in injury from the unit falling or tipping over.
Adjust the leveling feet by rotating them until they make contact with the floor. Ensure the unit level.

■ A location with adequate ventilation

- ⚠ Leave at least 10 cm around the unit for ventilation. Poor ventilation will result in a reduction of the refrigeration capacity..

■ A location not subjected to direct sunlight

- ⊘ Installation in a location subjected to direct sunlight may lead to inadequate cooling.

■ A location without flammable or corrosive gas

- ⊘ Never put volatile or flammable substances in this unit. This may cause explosion or fire.

■ Use a power supply plug with ground (earth) to prevent electric shock

- ⚠ **Use a power supply plug with ground (earth) to prevent electric shock.** If the power supply outlet is not grounded, it will be necessary to install a ground by qualified engineers.

■ Connect the unit to a power source as indicated on the rating label

- ⚠ **Connect the unit to a power source as indicated on the rating label attached to the unit.** Use of any other voltage or frequency other than that on the rating label may cause fire or electric shock.

- Install the unit to operate leakage circuit breaker



Install the unit to operate the leakage circuit breaker. The breaker is attached in the operation panel. Don't put something in front of the operation panel. Obstruction to operate the breaker may cause fire or electric shock

- A location away from heater generating sources



Avoid installing the unit near heat-emitting appliance such as gas ranges or stoves. Heat can cause inefficient refrigeration.

3. Caution for usage

- Before use



The freezer has been thoroughly cleaned before delivery, but we recommend cleaning it once more to be on the safe side.



Attach the shelves and baskets on each level in the freezer before starting cooling operations.

- During use



Never store corrosive materials such as acid or alkali where the container is not completely sealed. This could possibly lead to corrosion of evaporator resulting in refrigerant leakage and subsequent loss of cooling ability.



Do not allow chemicals and other liquids to spill directly onto shelves or inside the freezer. Immediately turn off the power and wipe up any spilled liquid.



Close the glass (outer) door after closing the acrylic (inner) door of the freezer. Closing the glass door without closing the acrylic door may damage the doors.



Open and close the doors quickly, and put in and remove items quickly. Minimize the number of times the doors are opened. Leaving the doors open for extended periods will cause the temperature inside the freezer to rise and delay freezer temperature stabilization.



Be careful not to get fingers caught in the doors when closing them.





Be careful not to bump your head while working with the inner door open.

 Keep everything inside the freezer neat and tidy and ensure air can pass through with sufficient ease. Keeping too much in the freezer or blocking the air ports may cause temperature destabilization.

■ **Always remember the following**

 **Do not use flammable spray like as lacquer paint, volatile or flammable substances on this unit.** This may cause explosion or fire.

 Do not allow water to directly contact the unit, and do not use water to wash the unit. This may cause shorts or electric shock.

 **Do not touch any electrical parts such as the power supply plug or any switches with a wet hand.** This may cause electric shock.

 **Never damage, break or bundle the power supply plug or cord. Do not use the supply plug if its cord is loose.** Putting heavy object on the cord cause fire or electric shock.

 **When removing the plug from the power supply outlet, grip the power supply plug,** not the cord. Pulling the cord may result in electric shock or fire by short circuit.

 Remove dust from the power supply plug periodically. A dusty plug or improper insertion may pose a hazard.





 If the unit is unplugged or the power to the unit is interrupted, do not restart the unit for at least 5 minutes. This protects the compressor.

 Periodically confirming a normal operation of the breaker. Disabled breaker cause electric shock

 **Contact local distributor or manufacturer when the breaker works.** Forcibly turning on may cause electric shock or fire.

 **Do not insert metal objects such as a pin or a wire into any vent, gap or any outlet for inner air circulation.** This may cause electric shock or injury by accidental contact with moving parts.

 Do not keep flammable items near the drain evaporating tray on the rear of the unit. This may generate heat and cause fires.

-  **Do not climb onto the unit.** This may cause damage to the unit.
-  **Do not touch condenser directly** when the filter is removed cleaning. This may cause injury due to hot surface.
-  **Dispose of any water in the evaporation tray completely before moving the unit.** Spilled or splashed water may cause current leakage or electric shock.
-  **Do not put the packing plastic bag used in the packaging within reach of children** as suffocation may result.
-  **Disconnect the power supply plug** when the unit is not used for long periods.

4. Introduction

- [1] Read this manual and its instructions carefully before using the equipment for safe operation.
- [2] Daido does not guarantee safety if the equipment is used for any purpose other than its intended use or if used by any procedures other than those mentioned in this manual.
- [3] Keep this manual in a suitable place to refer to as necessary.
- [4] The contents of the manual are subject to change without notice due to improvements to performance or functions.

5. Equipment Overview

This equipment can control temperature to $+4^{\circ}\text{C} \pm 2^{\circ}\text{C}$ (sensor temperature stability – stability when unloaded). Temperature is controlled via a refrigerant gas temperature control method used by a freezer. Hot gas bypass is used when only the compressor is used.

6. Front Panel Nomenclature

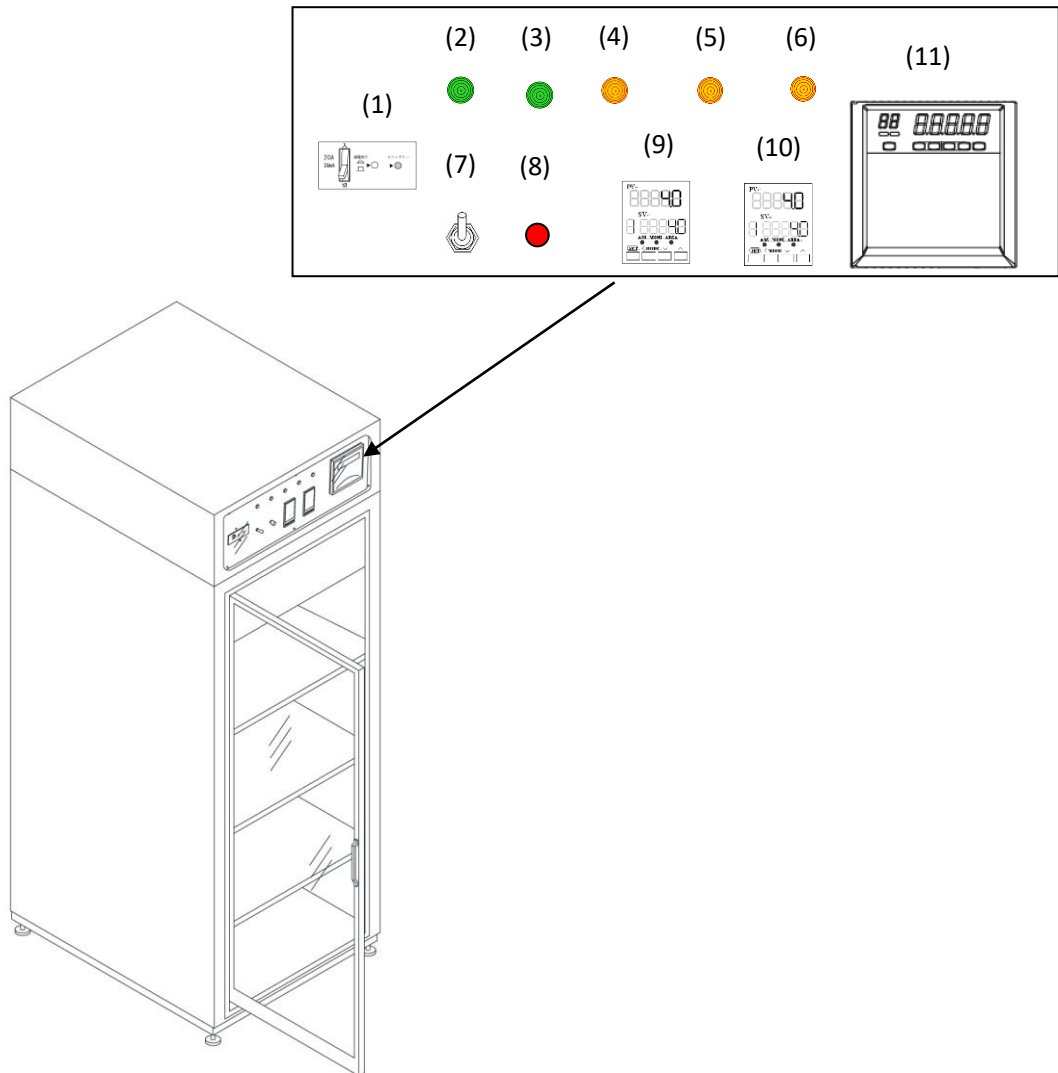

(1) Power switch (circuit breaker)

Circuit breaker operates and stops the supply of power when the equipment overloads or suffers a short circuit.

(2) Compressor lamp(green)

Lights when the operation switch is ON. Lamp will not light during defrosting process.

(3) Thermostat lamp (green)

Lamp will light green when temperature is being controlled by hot gas.

(4) High Temperature error lamp (orange)

Lights when a HIGH temperature error is detected by the thermostat, the alarm controller or the recorder.

(5) Low Temperature error lamp (orange)

Lights when a LOW temperature error is detected by the thermostat, the alarm controller or the recorder.

- (6) Compressor error lamp (orange)
Outputs an alarm when there is an overcurrent in compressor
- (7) Operation switch
Switches between operation and shutdown for Compressor
- (8) Reset and buzzer stop button
Stops the buzzer after it has sounded and enters forced operation for 30 minutes.
- (9) Thermostat with alarm
Displays and controls the temperature inside the refrigerator and alerts to abnormal temperatures.
- (10) Alarm controller
Displays the temperature inside the refrigerator. Separate from the thermostat, alerts to abnormal temperatures.
- (11) Thermograph
Automatically records temperature. See the thermograph operator's manual for more information on operation.

7. Before Operating

- 1) Connect to power source of single phase 220V 20A single circuit ground.
- 2) Turn (1) Power switch to ON.
- 3) Check that power to (11) Thermograph is ON.
- 4) Turn (2) Operation switch to ON.
- 5) Press (8) Reset and buzzer stop button once. (Cooling will begin after the unit has been reset and the buzzer stopped.)
- 6) Check the preset temperature about Thermostat. The temperature setting (SV) when shipped from the factory is 4.0°C.

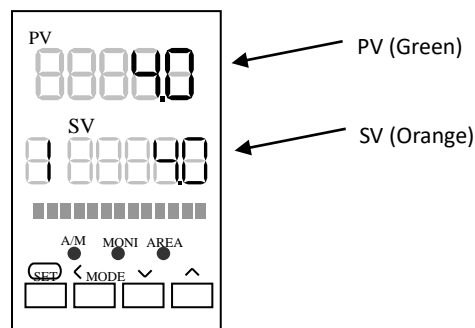

- * The warning buzzer may sound if the PV value (refrigerator temperature) is not within the alarm setting temperature range (+2.2°C to +5.8°C). Press (8) Reset and buzzer stop button to stop the buzzer. (The buzzer will sound again if the PV value (refrigerator temperature) is not within the alarm setting temperature range after 30 minutes.)

8. Shut Down

- 1) Turn (2) Operation switch to OFF.
- 2) Turn (1) Power switch to OFF.

9. Alarms

1) Temperature alarm

The temperature alarm is composed of three separate systems: (9) Thermostat, (10) Alarm Controller and (11) Thermograph.

When a high or low temperature alarm activates in either the thermostat or the temperature measured by the thermograph, then (4) High temperature error lamp will light for high temperature errors and (5) Low temperature error lamp will light for low temperature errors. The alarm delay timer will activate when the lamp lights, and a buzzer will sound once time is up.

Setting when shipped from the factory
(+4°C ±1.8°C)

High temp. alarm: +5.8°C
Low temp. alarm: +2.2°C

*The thermograph will output an alarm even if (7) operation switch are not ON. Turn the thermograph power OFF to turn off the temperature alarm.

Confirming Alarm Values

- Confirming thermograph alarm value

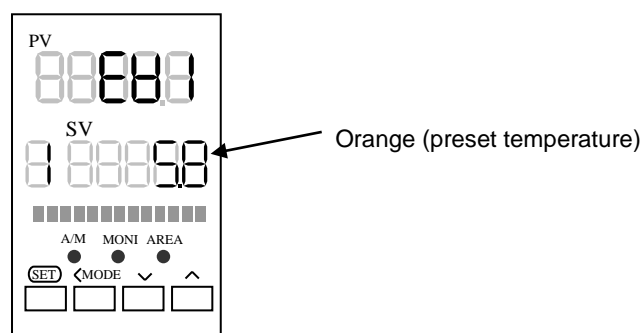

Pressing the SET button for two seconds or more to display EV1 in the PV value will allow you to confirm the high temperature alarm (5.8°C) in the SV value. Pressing the SET again to display EV2 in the PV value will allow you to confirm the high temperature alarm (2.2°C) in the SV value. Press the SET button for two seconds or more after you have confirmed the value to return to the original display.

➤ Confirming temperature recorder alarm value

1. Press the **MENU** key for three seconds to enter the setting mode.
2. Press the Δ or ∇ key, select ALARM, and press the return arrow key.



3. Select CH1 and press the return arrow key.
4. To confirm the high temperature alarm, select L1 and press the return arrow key.
5. Press the return key when "H" is displayed.
6. The high temperature alarm setting will display "5.8." Press the return arrow key until "OK" is displayed.



7. Select CH1 again and press the return arrow key.
8. To confirm the low temperature alarm, select L2 and press the return arrow key.
9. Press the return key when "L" is displayed.
10. The low temperature alarm setting will display "2.2." Press the return arrow key until "OK" is displayed.



Display during Alarms

An alarm will print when an alarm occurs or is canceled.

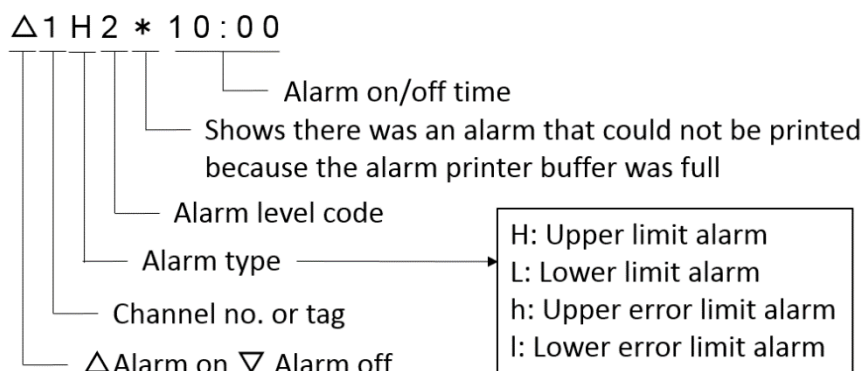

*Never change the temperature setting, alarm setting, or other values. Doing so may cause an alarm not to sound at the expected temperature or upset the operating balance and cause harm to the unit.

2) Forced stop

A safety device that forcibly stops the freezer will activate if the temperature reaches the low temperature cut setting or the high temperature cut setting.

Pressing the reset and buzzer stop button will start forced operation for 30 minutes. Contact your dealer or the manufacturer if forced stops occur frequently with the compressor.

Refer to 1) temperature alarm to confirm alarm values.

Settings when shipped from factory
(+2°C, +12°C)

High temp. cut setting: +12.0°C
Low temp. cut setting: +2.0°C

You can check the high temp. cut setting (+12.0°C) by pressing the SET button for two or more seconds to change the PV value to EV3, or check the low temp. cut setting (+2.0°C) by changing the PV value to EV4.

Once you have confirmed the setting, press the SET button again for two or more seconds to return to the original display.

Note: No alarm will sound (except for the power failure alarm) if (7) Operation switches are OFF.

*Never change the alarm settings or other items. Doing so may upset the operation balance and cause failure.

3) Compressor error

Outputs an alarm when there is an overcurrent in compressor. Contact your dealer or the manufacturer if forced stops occur frequently with the compressor.

10. Defrost

Compressor will automatically defrost every two hours. (2) Compressor operation lamps will not light during the defrosting process.

11. Circuit breaker

Should the unit overload or short circuit, (1) Circuit breaker will operate (breaker switches will be in the off position) and power supply will stop. Investigate the cause, resolve the issue, and then reset the circuit breaker. (An external alarm will be outputted when power supply stops.)

12. Temperature precision

Temperature precision (temperature error)

Maximum error (allowable value) includes the precision of the sensors, electronic digital indicator controller (thermostat), and electronic thermograph (thermograph). Calculated values are shown as the maximum possibility of error.

Thermostat/alarm controller

Sensor: Resistance temperature detector, Pt100Ω Class A (1)

Electronic digital indication controller: RKC Instrument, Inc. FB Series (1)

Operating temperature: 4°C

Sensor: $\pm (0.15 + 0.002 \times |4|) \cong \pm 0.158$

Thermostat: ± 0.2

$$\therefore \pm (0.158 + 0.2) = \pm 0.358^{\circ}\text{C} \cong \pm 0.4^{\circ}\text{C}$$

Thermograph

Sensor: Resistance temperature detector, Pt100Ω Class A (3)

Electronic thermograph: Yokogawa Electric Corp. SR10000 Series (1)

Operating temperature: 4°C

Sensor: $\pm (0.15 + 0.002 \times |4|) \cong \pm 0.158$

Thermograph: $\pm (0.15 / 100 * 100 + 0.3) = \pm 0.45$

$$\therefore \pm (0.158 + 0.45) = \pm 0.608^{\circ}\text{C} \cong \pm 0.7^{\circ}\text{C}$$

13. Care

Caution

- (1) Always unplug the unit before care and maintenance.
- (2) Do not allow water to directly contact the unit, as this may short circuit or harm the equipment.

Exterior/Interior care

- (1) Use a neutral detergent on a soft cloth to wipe away grime.
- (2) Next, wipe with a cloth soaked in cold or warm water and thoroughly wipe away any remaining detergent.
- (3) Finally, wipe with a dry cloth to remove any remaining water and let the unit dry.

14. When Not Using

When not using for extended periods:

- (1) Unplug the unit.
- (2) Remove all items stored in the freezer and ensure that it is empty.
- (3) Clean the unit thoroughly as described in 13. Care.

15. Troubleshooting

Before requesting maintenance,

(1) Read the following regarding common issues. (See 9. Alarms should an alarm occur.)

Situation	Solution
The switch is on, but the digital display does not turn on.	<ol style="list-style-type: none"> 1) Is the power system on? 2) Is the unit plugged in? 3) Has the circuit breaker been tripped? 4) Noise may be affecting the thermostat. Turn the switch off and on again.
A temperature alarm sounds every two hours	There may be a problem with the compressor. Contact your dealer or the manufacturer.
The digital display works, but unit is not getting cold	<ol style="list-style-type: none"> 1) Are the doors open? Check whether the doors are securely closed. 2) Is there something blocking the air ports in the freezer? 3) Check whether there is any debris in the condenser at the compressor unit that may be causing poor heat radiation. If there is debris in the condenser, unplug the unit and remove the debris with a vacuum cleaner or the like. 4) Check whether there is ice on the cooler (inside the cover on the chamber ceiling). While the unit automatically removes frost at the cooler, the frost will ice in extremely humid environments, causing poor air circulation in the cooler and preventing cooling. Turn off the power in this situation and defrost the unit. 5) Check whether the freezer air conditioning is operating properly. Cooling capacity will decrease if the freezer cannot radiate heat.
The digital display is on but the unit is too cool	The Power Relay is exhausted or broken. You will need to contact your dealer for a replacement SSR.
There is frost around the door	Is the door heater off?
The unit is loud	Is the floor sturdy and level?
	Are there screws or other parts loose?

(2) If you still cannot resolve the problem, unplug the unit and contact your dealer with the following information. Do not use broken.

- Product model, serial number, and date purchased
- Nature of the problem (be as specific as possible)

*The warranty period for this product is one year after delivery.

16. Specifications

Product Name	Blood Bank Refrigerator
Model	DRS-500
External dimensions	W754 x D1100 x H1848 (mm)
Capacity	520L
Input power source	1 ϕ 220V 50Hz (Sine Wave)
Starting Current	16A
Interior/exterior	SUS304 stainless steel plates
Shelving	SUS304 stainless steel plates(4)
Door	Vacuum insulated double glass door(1)
Inner Door	Acrylic Plate(2)
Cooling system	Refrigerant Gas Temperature control and horizontal laminar air flow
Heat radiation	Air cooled condenser
Compressor	1 ϕ 220V 450W, air cooled
Refrigerant gas	R-404(HFC)
Internal fan	33W (4)
Evaporating Heater	200W
Thermostat (with alarm)	Electronic digital indication controller: 1 Sensor: Resistance temperature detector, Pt100 Ω Class A
Alarm Controller	Electronic digital indication controller: 1 Sensor: Resistance temperature detector, Pt100 Ω Class A (1)
Thermograph (with alarm)	Electronic hybrid thermograph: 1 Sensor: Resistance temperature detector, Pt100 Ω Class A
Alarms	<ul style="list-style-type: none"> • Internal temperature alarm Thermostat and alarm controller are separate. Detects and outputs an alarm (high temperature). Settings when shipped: High temperature alarm: +5.8$^{\circ}$C Low temperature alarm: +2.2$^{\circ}$C • Compressor error • Power failure alarm output
External alarm	Non-voltage contact A
Protectors	The freezer forced stop function (forces the freezer to stop when there is a high or low temperature error) and thermostat detect independently and will sound an alarm if they detect an error. (High/low temp. cut) Setting when shipped from the factory { High temp. cut setting: +12.0 $^{\circ}$ C (+2 $^{\circ}$ C, +12.0 $^{\circ}$ C) } Low temp. cut setting: +2.0 $^{\circ}$ C
Operating conditions	<ul style="list-style-type: none"> • Operating environment: Indoor use, 2000m or below • Ambient temperature range: 5 – 30$^{\circ}$C • Maximum ambient humidity range: 80% RH
Weight	260kg